



Fall 2014

# HELL YES Raygun's Creation, Success & Future



CHANGING THE WORLD  
**It Only Takes One**

AN UNLIKELY VINEYARD  
**The Tale of Tassel Ridge**

FIVE STEPS  
**To Protecting What's Yours**

[www.dmacc.edu/ci](http://www.dmacc.edu/ci)



# Renew Your Passion



Let the INS Family of Companies deliver the talent, technology and tools you need to focus on your business. And be prepared to smile!

THE **INS** FAMILY OF COMPANIES



IowaNetworkServices.com/passion • 800-CALL-INS

# One experience for everything in your life

Come to Microsoft and check out Surface Pro 3, Windows Phones, and more

## Microsoft at Jordan Creek Town Center

101 Jordan Creek Parkway  
West Des Moines, IA 50266



Some apps sold separately. Some features require Windows 8.1 Update, available through Windows Update. Internet access required; fees may apply.

# FEATURES

## 7 | Hell Yes

RAYGUN's Creation, Success and Future

BY MIKE DRAPER

## 13 | It Only Takes One

BY DR. ANTHONY PAUSTIAN

## 21 | An Unlikely Vineyard

The Tale of Tassel Ridge

BY BOB WERSEN

## 29 | Five Steps

To Protecting What's Yours

BY KIRK M. HARTUNG

Celebrate! Innovation Magazine is published biannually by Des Moines Area Community College West Campus. For advertising or content inquiries, contact:

Dr. Anthony Paustian  
Provost, DMACC West Campus  
5959 Grand Avenue, West Des Moines, Iowa 50266  
515-633-2439  
adpaustian@dmacc.edu

### CONTRIBUTORS:

Publisher: Anthony Paustian, Ph.D.  
Co-Editor: Beth Baker-Brodersen  
Co-Editor: Seeta Mangra-Stubbs  
Designer/Production: Amina Miraj Ali

### COVER PHOTO:

A cover of RAYGUN's first catalogue after changing the name in 2009. Photo: Dan McClanahan. Used with permission.

©Copyright 2014 Des Moines Area Community College

**NONDISCRIMINATION POLICY:** Des Moines Area Community College shall not engage in or allow discrimination covered by law. This includes harassment based on race, color, national origin, creed, religion, sex (including pregnancy and marital status), sexual orientation, gender identity, age, disability and genetic information. Veteran status in educational programs, activities, employment practices, or admission procedures is also included to the extent covered by law. Individuals who believe they have been discriminated against may file a complaint through the College Discrimination Complaint Procedure (ES4645). Complaint forms may be obtained from the Campus Provost's office, the Academic Dean's office, the Judicial Officer, or the EEO/AA Officer, Human Resources. For requests for accommodations, the Accommodation/Section 504/ADA Coordinator can be contacted at 515-964-6857. For Title IX questions and concerns, contact 515-964-6850



# EDITOR'S NOTE

## “One Does Not Simply Walk” ... into Success

In the film version of *The Lord of the Rings: Fellowship of the Ring*, the fellowship visits Lothlórien to see Galadriel, the elven queen (stick with me, non-nerds). The hobbit, Frodo Baggins, uncertain about the task of throwing the Ring of Power into Mount Doom, says to the queen, “It’s just . . . I’m afraid to do it.” Galadriel, who towers over Frodo, crouches to meet his eyes and says, “Even the smallest person can change the course of the future.”

The authors in this edition of *ciWeek Magazine* are, as far as I know, neither hobbits nor wispy elves. But they embody Lady Galadriel’s message and the importance of it.

Be it through starting a small business or helping others start theirs, our contributors recognize that any person can take a journey like Frodo’s and achieve it through small steps. Tassel Ridge Winery owner Bob Wersen details how he and his wife started an Iowa winery and faced unexpected obstacles. Intellectual property law

expert Kirk Hartung explains the minutely detailed but essential route to obtaining a patent, demonstrating the careful considerations new business owners and inventors must take. Our own Dr. Anthony Paustian addresses the practical side of inspiration and how it gives us the push out the door to start our innovative journeys. And RAYGUN owner Mike Draper takes us through his voyage of one guy in a t-shirt shop to a beloved, multi-state retail store.

It’s in Draper’s piece that I find the most intriguing parallels. He writes about his business’s growth alongside that of Des Moines’. As a Des Moines native, I distinctly remember each of the steps Draper notes of the city’s trek from boring town to thriving metropolis. Rarely during my childhood do I recall the resident hobbits of Des Moines proudly baring our big hairy feet to tell anyone where we were from (and when we did, we said Iowa, only to be asked if that’s where we grew potatoes). Today, because of the inspiration of individuals

like Draper, Desmoians display the Traveler’s umbrella, the Weather Beacon (long live the Weather Beacon), and the city’s name with honor.

All of our contributors, like Frodo and the residents of Des Moines, faced—and will continue to face—uncertainty. But through the obstacles, the Gollums and the Shelobs (why did it have to be spiders?) all proved that success is obtainable. With the right resources and a lot of inspiration, anyone reading this magazine can set out to save Middle Earth. Or at least your version.



Seeta Mangra-Stubbs is an instructor of writing at the DMACC West Campus. She may be reached at [slmangrastubbs@dmacc.edu](mailto:slmangrastubbs@dmacc.edu).

# Innovating since 1893

Sometimes the most innovative thing we can do is keep doing the right things.

At West Bank, we've spent more than a century building strong relationships one handshake at a time. With each handshake an innovative new business or family venture is launched. We're proud to play a role in each new dream, just like we did back in 1893.



[www.WestBankStrong.com](http://www.WestBankStrong.com)

Member FDIC |



screenprinted  
info inside



RAYGUN

white tag  
on back  
of every pair

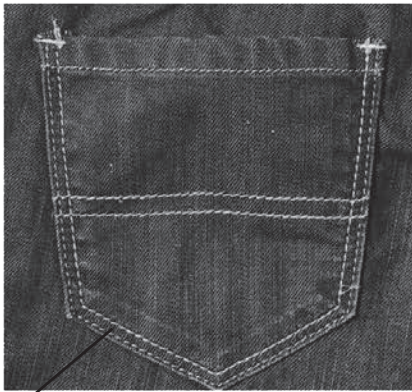

simple pocket design



our own line of simple, affordable,  
RAYGUN brand jeans are shipping  
to us right now and will arrive soon!

there will be 3 styles for girls  
and 2 styles for guys.



customized right down  
to the buttons and rivets

Initial promotion materials for RAYGUN's line of jeans from 2012. Photos: Mike Draper. Used with permission.



BY MIKE DRAPER

# HELL YES

*RAYGUN's Creation, Success and Future*

*My life's ambition was not to make and sell t-shirts. It's a profession that lacks sex appeal, that's for sure. There aren't a lot of movies where the disgruntled, youthful protagonist throws caution to the wind and forsakes his small-town life and conservative family for the promise of t-shirt-based celebrity.*





Rendering of RAYGUN's new building at the corner of East 5th and Grand in Des Moines. Image: Invision Architecture. Used with permission.

Of course, it's also hard to imagine a movie where the disgruntled, youthful protagonist throws caution to the wind and tells his family, "I don't care what you say, Mom and Dad. I'm leaving the East Coast and moving to Des Moines."

"I'm sorry, son, but did you say, 'Des Moines?'"

"Yeah, I did. I said I'm leaving the East Coast and moving to Des Moines."

"Okay, but your mother and I just aren't getting it. Are you saying you want to be an actuary or something? You're ready to settle down and raise a family in a place with low crime, good public schools and a moderate standard of living? That would actually kind of please us."

In 2005, I was living in New York, when I decided to defy expectations by moving to the Midwest to open RAYGUN, a company that would make and sell...t-shirts.

Of course, my notion to return to middle America wasn't that far out of left field.

I'd grown up outside Des Moines, graduating from Van Meter in 2000. But after my high school graduation, I left Iowa to study history at the University of Pennsylvania in Philadelphia and St. Andrews University in Scotland.

*We are a piece of  
a landscape that  
changed dramatically  
in about a decade.*

My studies—though prestigious—hadn't exactly prepared me for a life of commerce. I graduated in 2004 without having taken any business or design courses (let alone screen printing). I never worked in retail, didn't particularly like shopping, and did little-to-no market research about starting a company in Des Moines.

For whatever reason, investors weren't lining up.

I couldn't even give away shares of the company. Four friends turned me down for a percentage of the company if they would just help me out and work in the store.

But I chugged along. I learned to print. I set up a website and a print shop in my parents' basement, and finally opened RAYGUN in September of 2005 in Des

Moines' East Village. The store was staffed by only one (albeit, extremely personable and handsome) employee.

RAYGUN opened in a newly constructed building at the corner of East 4th and Locust, with retail on the ground floor, residential on top. It seems basic now, but in 2005, that was the first mixed-use building in downtown Des Moines in more than 30 years. The nine stores that opened in our building almost doubled the size of the East Village.

I lived in the Vine Street Lofts, which also opened in the spring of 2005, the first new apartment project built downtown in decades. The Full Court Press guys opened The High Life Lounge, but there was no El Bait Shop, no Mullets, no Fong's, no Shorty's. The Continental opened that summer, so did House of Bricks. Salon W opened that fall.

Centro, Starbucks, the Royal Mile, Vaudeville Mews, The Lift and The Science Center were all less than three years old.

There was no Gateway Park yet, no Sculpture Park, no new Downtown Library, no World Food Prize Headquarters. The Des Moines Social Club didn't exist, and neither did Zombie



Burger, HOQ, Django, Alba, Proof, or Dos Rios. No Mars Cafe, no 80/35 Festival, no Americana, no Wooly's, no Gusto Pizza Co., no West End Salvage, no Exile Brewing.

But that would soon change, although slowly at first.

Over the last nine years, RAYGUN has not expanded in a vacuum. The company's rise has often paralleled downtown Des Moines' rise.

2005–2007 were good years, but fairly lonely. It was still just me working in the store. The first employees were hired in 2007.

2008 was a year of expansion. Obama won the caucus in January, and in February, we doubled the size of the store. That summer was the first 80/35. We printed shirts for it.

In 2009, the company expanded again, covering 4,500 square feet and employing ten people. I divided the company into two: RAYGUN (retail and retail print-design) and 8/7 CENTRAL (which printed for other people, companies, etc.).

In 2010, I sold 8/7 CENTRAL and expanded RAYGUN into Iowa City. Our book followed in 2012, and RAYGUN Kansas City opened in the spring of 2014.

When we hit our ten-year anniversary in 2015, we'll be in a 6,000-square-foot space in the East Village, and between my company and 8/7 CENTRAL, there will be more than 30 employees and in excess of \$3.5 million in total sales.

Things have gone well, but we are a piece of a landscape that changed dramatically in about a decade. Almost all major attractions downtown Des Moines offers are roughly the same age as RAYGUN.

To my surprise, I've found managing RAYGUN, today a decently sized company, almost harder than managing RAYGUN as a start-up.

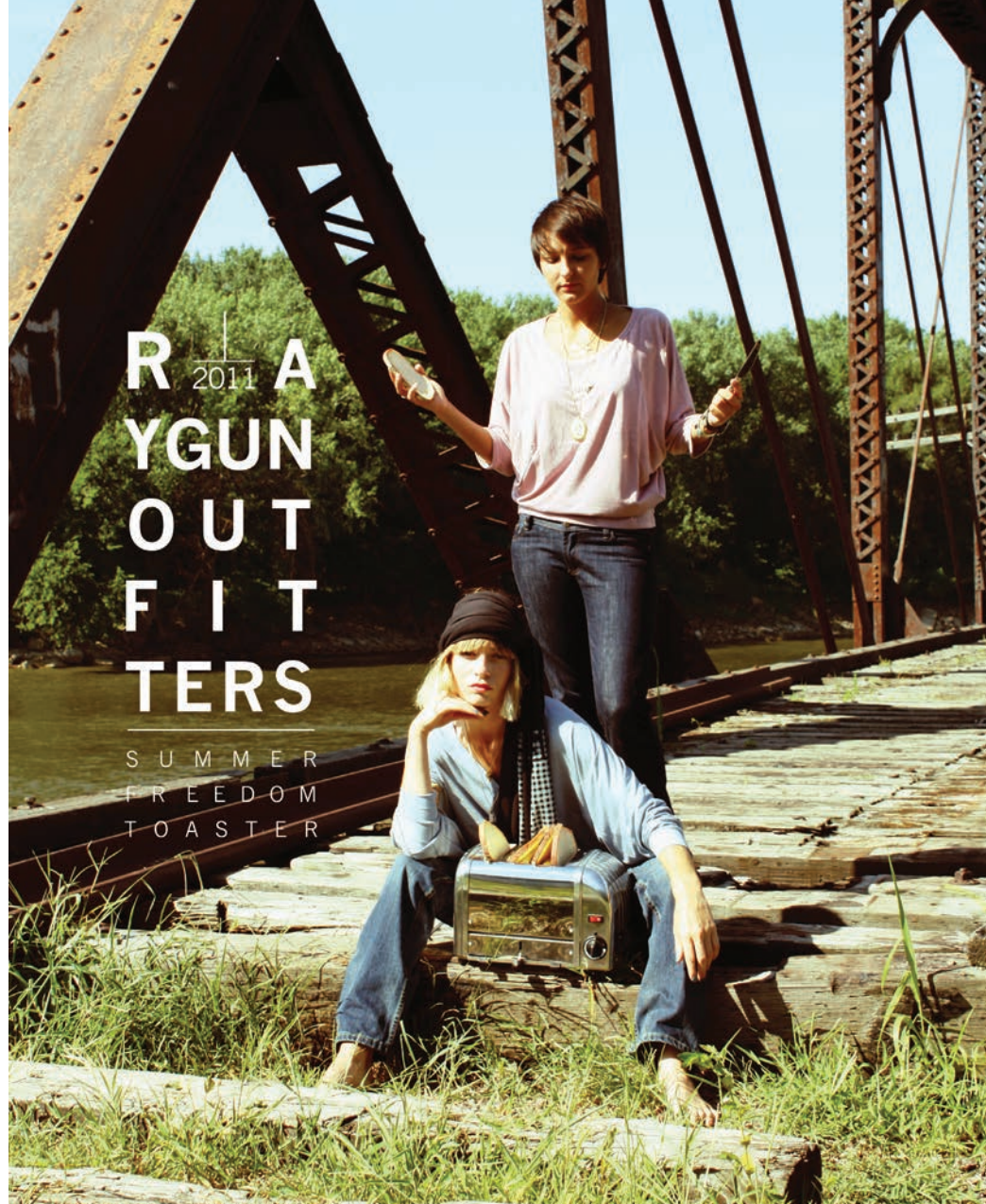

Lucy Shay and Betsy Pearson pose for RAYGUN's spoof on Urban Outfitters' habit of putting models in the middle of nowhere. Photo: Mike Draper. Used with permission.

For one, the math is more difficult. When RAYGUN began, I had about \$2,000 to \$3,000 worth of inventory. Not too tricky to manage that, really. And what I did have sold *slowly*. Now, we keep about \$250,000 to \$300,000 worth of inventory in stock. The swings in that inventory and the costs required to expand not only make the math more complicated but also impossible to know for sure. We can calculate our expenses and start-up costs, but we still don't know if people will shop there.

A pressure for RAYGUN to succeed exists today that didn't before. If a start-up fails, it's "No big deal, man,

lots of start-ups fail; you can always do something else." If a known company with a popular product fails, it's "The guy who ran that place must have been a dumbass!"

And finally there is a formula. Our brand helps us sell product and frames our style. But it's different from the early days when we could throw ideas at the wall and see what stuck. Now, the whole team has to be on the same page, designs and postings approved, moves planned out.

Des Moines faces a similar challenge. Ten years of success can make next moves more difficult, because at the





RAYGUN t-shirt. Used with permission.

heart of it, for Des Moines or RAYGUN, no one can fully explain the success. If you were 100 percent certain what worked in the past would work in the future, you'd do that over and over again. All you can do is use evidence from the past to make your best guess at forward progress.

But with ten years of success, there is still the risk that new progress will undermine or even destroy past success. Sitting on my hands isn't an option, though. RAYGUN succeeded as Des Moines succeeded, but both succeeded during a national shift toward downtown environments and local products. Once-dead downtowns sprang to life from Hartford to Little Rock, Fargo to Kansas

City. Alongside their growth are familiar faces: farmers' markets, craft beers, local restaurants with locally sourced ingredients, local boutiques, and even local-pride t-shirt shops.

Fargo has TAG T-shirts. Northern Michigan has M-22. STL Style in St Louis, CLE Clothing in Cleveland, Ink Detroit, Homage in Columbus, and many more. All of us benefited from the general "buy local" trend. But what does the second phase of that trend look like?

I once told an employee that we had to grow because "three 23-year-old guys working in a t-shirt shop can be cool, but three 43-year-old guys working in a t-shirt shop is definitely not cool."

It's hard to keep your own interest, let

alone retain other talented people, if you're doing the same thing year in and year out with no upward movement, no outward expansion.

I want RAYGUN to become a Midwestern brand based in print-design. Third-party brands would fill out the stores, but the focus would be slogans on t-shirts, koozies, posters, coasters, pint glasses, mugs, notebooks, and nearly anything we can stick a slogan on.

Along those lines, we'll produce our own books like *The Midwest: God's Gift to Planet Earth* and use a product like that to spin off video or animation work. There could be digital publications, radio shows—a kind of Urban Outfitters meets *The Onion* and then spends time with *A Prairie Home Companion*.

But everything would be distributed through a network that RAYGUN controls.

Distribution seems boring, but it's what I think about a lot. Distribution and product production are often viewed separately.

I viewed them that way in the beginning. I figured I'd design and make the shirts, then I'd sell them to stores or websites that would sell them to customers. Etsy, Zazzle, Cafe Press and Threadless all play to this mentality: you design it; we distribute it.

Distribution is expensive, but the money and product to control it trump all else, in my book.

At RAYGUN, we continue to sell our products mainly through our stores and website. When we wholesale our products, we do it only to small stores, not to national chains or publicly held companies.

RAYGUN will stay in the 12-state Midwest only, but we aim to be a hub of activity in any city where we set up. We hope to be an inspiration to other entrepreneurs to say you don't have to use someone else's distribution channel; you can take your product directly to the people.





Mike Draper and Jen Mitchard spoof Abercrombie & Fitch for a RAYGUN catalogue. Photo: John Bosley. Used with permission.



In 2005, Mike Draper moved back to Iowa from Philadelphia, opening RAYGUN in downtown Des Moines. Since then, the company has grown steadily, spinning off its custom printing and design side into 8/7 Central, opening a second and third RAYGUN in Iowa City and Kansas City, and writing a book, *The Midwest: God's Gift to Planet Earth*, that a couple people read.

Sales have reached around \$3 million, employee totals have passed 30, but the company goals remain humble: make people laugh, make Draper disgustingly rich, and save America from a thousand years of darkness.

<http://raygunsite.com/>

Consider the subscription model. People used to have dozens of subscriptions (newspapers, magazines, etc.), and those faded as things boiled down to two: Internet and cable.

Now subscriptions are proliferating again within the Internet. Ten years ago, I paid for only the Internet each month. Now I pay for the *New York Times*, the *Des Moines Register*, Netflix and Hulu each month (on top of the Internet).

Perhaps RAYGUN will use a t-shirt club as a gateway subscription service; we'll still have a website where people can peruse items, stores, etc. However, we'll have a blog section closed to subscribers only. With that money, we

could write, illustrate or shoot content. Subscribers could also get a free shirt as something tangible, if they wanted, each month.

None of those ideas are new, just modified to fit the new technology.

Hopefully, we can be one of the first in a long line of self-distributed, subscription-based stores. Instead of creators all funneling through the same dozen channels—Etsy, Amazon, etc.—they can set up their own distribution network in a world where customers are used to having subscriptions to more than a dozen websites that have physical or digital content.

But like Space Invaders, business is the game that moves as you play. The landscape is shifting, and RAYGUN has to shift with it. Our problem is not a lack of ideas, but rather picking the right ideas at the right time and implementing them successfully.

I can only explain about 70 percent of RAYGUN's success. That mystery 30 percent will never be known to me. That encapsulates the risk and the excitement of this project. In the words of the song, "Everybody's Free to Wear Sunscreen," "The race is long, and in the end, it's only with yourself."



# Positioned. *Perfectly...* *for Innovation*



## WEST DES MOINES

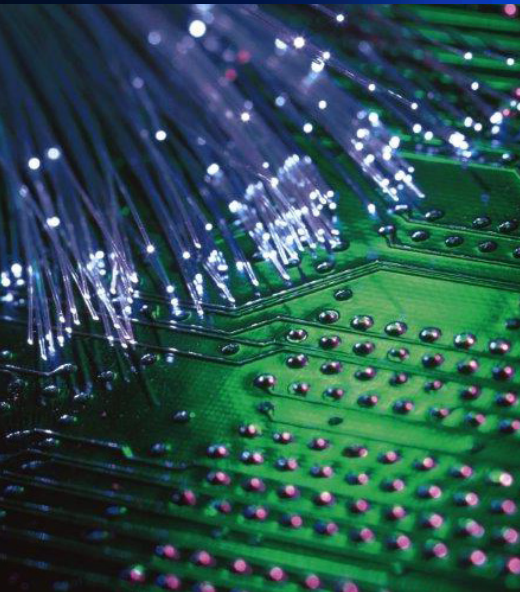

West Des Moines, Iowa

515-273-0770

[www.positionedperfectly.com](http://www.positionedperfectly.com)



A. B. STROWGER.  
AUTOMATIC TELEPHONE EXCHANGE.

No. 447,918.

Patented Mar. 10, 1891.

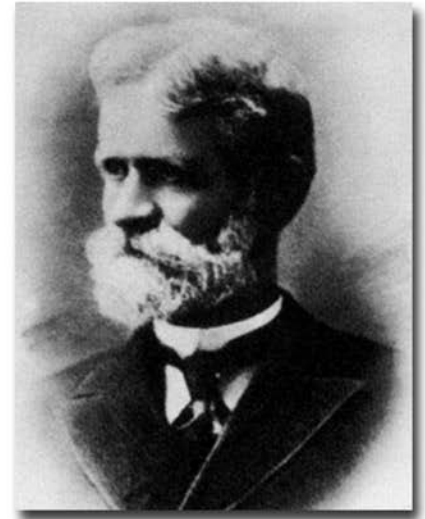
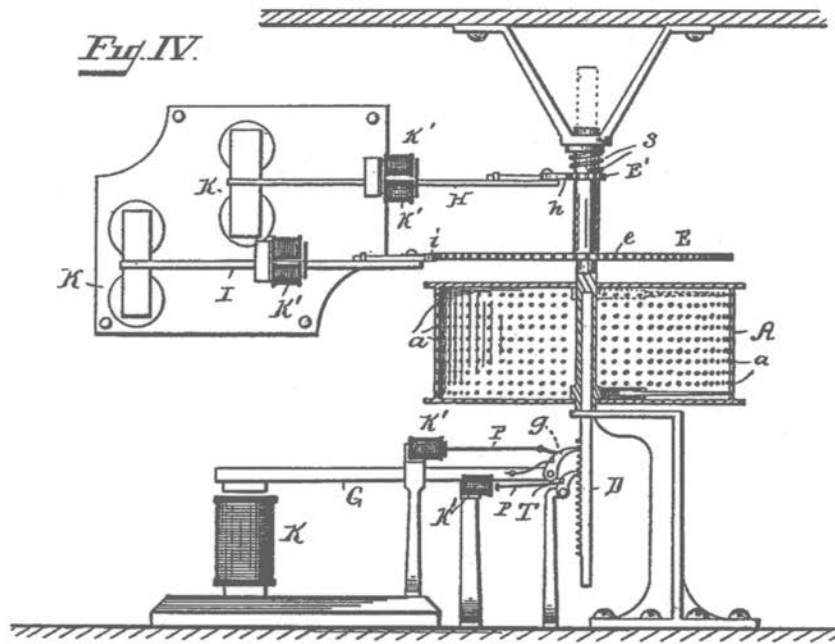

BY DR. ANTHONY PAUSTIAN

Patent diagram of Almon Strowger's game-changing idea. Used with permission.

# IT ONLY TAKES ONE

*In the late 1800s, a Kansas City undertaker by the name of Almon Strowger was inspired to change the process by which telephone calls were routed. At that time, telephone calls were routed by a human “cord board” operator who would listen to the caller’s request and subsequently connect the caller by manually plugging a cord into the slot that would send the call. In Strowger’s situation, the operator in town was the wife of his primary competitor. Strowger became convinced the operator was directing all calls for an undertaker (even if they asked for Strowger directly) to her husband. Despite many complaints to the Bell System company, nothing changed. Strowger then became inspired to invent the automatic telephone switch, which removed the need for a human being to manually connect calls. This invention, by an inspired man with absolutely no background or formal training in this technology, revolutionized the telecommunications industry.<sup>1</sup>*





West Campus student using an iPAQ Pocket PC. Used with permission.

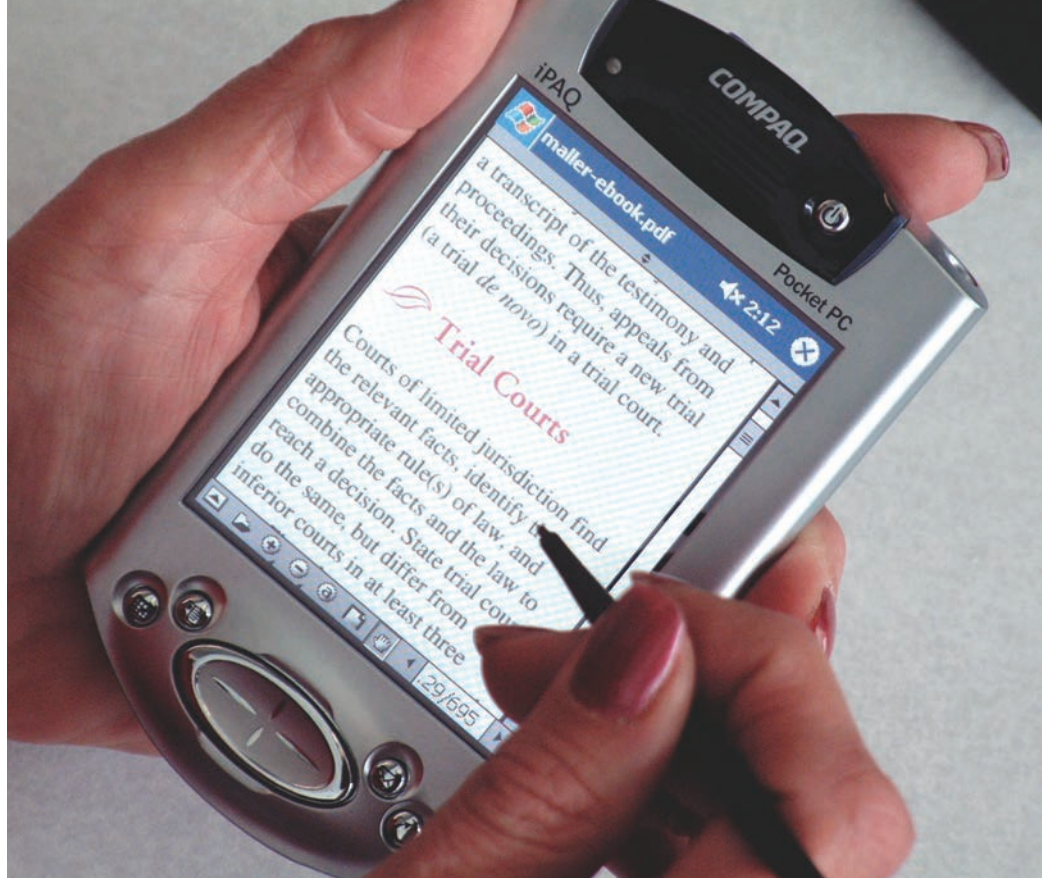

iPAQ PocketPC displaying business law textbook. Note the stylus pen, as touchscreens didn't yet exist. Used with permission.

In *Beware the Purple People Eaters*, I define inspiration as the drive behind creativity, the internal motivation that causes one to make new connections between seemingly unrelated things.<sup>2</sup> Occasionally, inspiration occurs as the result of something else, when the desire to do or change something in the current situation becomes necessary to avoid the growing pain of remaining the same.

In a *Harvard Business Review* blog, Scott Kaufman writes, “In a culture obsessed with measuring talent and ability, we often overlook the important role of inspiration. Inspiration awakens us to new possibilities by allowing us to transcend our ordinary experiences and limitations.”<sup>3</sup>

In 1999, I was hired to oversee the development, planning, and preparation for the opening of what would become the West Des Moines Campus of Des Moines Area Community College. The focus at that time was to create something different: a new, unique learning environment with a strong emphasis in technology.

I was inspired.

Through the hard work and efforts of a great team of motivated people, the result was the creation of a unique physical facility: one with angular walls, a bunch of glass, and an open-learning environment (to this day we still refer to the campus as the “mothership”). Amenities included a trendy cyber-café, outdoor activities including basketball, sand volleyball and Frisbee golf, and other student-focused activities, many designed to appeal to the tech-savvy student. All programs offered on campus were technology-focused including web development, programming, data networking, and telecommunications (liberal arts and business administration were added later).

From a tech perspective, the campus was ahead of its time. It was not only one of the first all-wireless college campuses, but according to two of our initial partners, Compaq (now part of HP) and Microsoft, it was also the first campus to fully utilize handheld technology (iPAQ Pocket PCs) to deliver

course content (all students within the tech programs received an iPAQ). With both forms of these technologies in their infancy, we also had to develop the software that allowed the iPAQs to wirelessly communicate with the servers. At the same time, we created an application that allowed faculty the ability to quiz students in real time with an immediate combined class outcome, which supplied faculty with instant feedback on student comprehension. eBooks didn't exist yet, and because of Napster and other Internet-based music pirating, publishers wouldn't allow us to use their content in this format. Therefore, campus faculty had to write and create eBooks for their courses.

Today these “cutting-edge” technological advances seem commonplace (a tribute to Moore's Law).<sup>4</sup> At the time, however, the campus was frequently showcased by national media such as CNN, CNBC, *USA Today*, NPR, and *Wired* for its innovative approach to changing the educational environment. In 2002, the campus





Apple cofounder Steve Wozniak speaking at ciWeek 3 in 2012. Used with permission.

was listed as number 51 on *InfoWorld's* top 100 list of the most innovative organizations. The only other educational

*Creative and innovative thinking are critical to both personal and organizational long-term success.*

institutions recognized were Harvard, MIT, and Penn. The list also included NASA, GE, Boeing, Verizon, BMW, FedEx, and Southwest Airlines.<sup>5</sup> Not bad for a community college in Iowa.

In 2006, ACT (among others) reported a serious decline of students entering STEM fields (Science, Technology, Engineering and Math).<sup>6</sup> This news, combined with an article I read about



Students observing one of the PC history cases. Used with permission.

how the learning environment affected motivation, inspired me again.<sup>7</sup> I became convinced an environment where technology was creatively used wasn't enough to motivate students, let alone encourage them, to enter STEM fields (plus, we lacked unlimited human and financial resources to continue blazing new trails). I developed a belief that students, and people in general, needed to be continually reminded that creative and innovative thinking are critical to both personal and organizational long-term success; they needed to understand how the innovative spirit has been a key element of what made this country great.

The result was the creation of the Celebrate! Innovation™ Exhibition: an interactive learning environment that focuses on telling stories of creativity and imagination. The narratives are about people who were inspired to do things most other people believed impossible. The exhibition is still going strong. Today's visitors learn how people from a variety of social, educational,

economic and ethnic groups have risen above the odds to take risks, motivate change and add value to everyday life.

The stories are told through two methods: the physical space and personal interaction. In the physical space, students and campus visitors are engulfed by tangible displays of personal innovation that serve as reminders of human potential. Whether it's an interactive exhibit of how the personal computer came to be, a visual timeline of how communication evolved from the telegraph to the modern-day Internet, wall-to-wall visuals combined with video documentaries of the people who made a difference, or the biannual *Celebrate! Innovation Magazine*, the stories surround visitors with the intent of initiating conversations and prompting questions toward personal discovery.

However inspiring, the physical space may be, I believe the most meaningful approach to storytelling is interaction with the people who are the stories: current, living creators of new ideas and



The history of communications exhibit detailing the changes spanning 150 years from the telegraph to the Internet. Used with permission. Photography by Jennifer Coleman.

developers of the latest innovations. Through engagement with the “who behind the what,” the stories come alive, which creates an emotional impact.

Our annual ciWeek (Celebrate! Innovation™ Week) provides students and the community opportunities to engage with people (some famous, all inspired) who have dreamed, created, and accomplished. It’s a thought-provoking and interactive week, where students listen, absorb, and engage without the stress of the regular class routine (classes are suspended for two days to allow students’ undivided attention). Generous sponsors make the event *free* to all attendees.

Previous ciWeek presenters have included two of the 12 men who walked on the moon; the man considered the father of the personal computer; television personalities who focus on science, invention and ideas; explorers who have been to the depths of the ocean to the highest mountain peaks; engineers developing the growing commercial space industry; inventors of incredible animatronics and robotics; Academy Award-winning visual effects creators and animators, and cheese and wine connoisseurs.

Topics and activities of the Celebrate! Innovation™ Exhibition and ciWeek appeal to diverse interests, experiences, and ages (students, professionals, seniors, and children). Events take place over four days and evenings with a shared goal of inspiration, learning, and fun.

Each year after ciWeek, people personally share how the experience changed their lives. I frequently observe people studying the CI exhibits, plus I have the pleasure of reading student papers and projects about the positive influence of the event.

It only required Steve Jobs to begin Apple Computer, Henry Ford to develop a new method of automobile production, Jonas Salk to create the polio vaccine, Hedy Lamarr to invent spread spectrum technology (the foundation of cell phone technology), Fred Smith (founder of FedEx) to envision overnight shipping, and Gene Roddenberry to imagine the technological future in *Star Trek*.

Thousands of people are touched each year by ciWeek and the Celebrate! Innovation™ Exhibition. Since any one of them could be inspired to invent or create something new to change our lives for the better, *isn't one enough?*

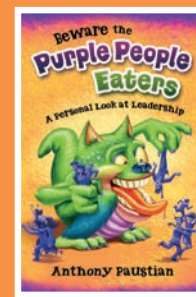

Dr. Anthony Paustian is the Provost of the DMACC West Campus and the author of *Beware the Purple People Eaters: A Personal Look at Leadership*.

[www.dmacc.edu/west](http://www.dmacc.edu/west)

[www.adpaustian.com](http://www.adpaustian.com)

©2014 Anthony Paustian. Used with permission. All rights reserved.

### References

1. Paustian, Anthony D. (2012). *Beware the Purple People Eaters: A Personal Look at Leadership*, Des Moines, IA: BookPress Publishing, p. 9.
2. Paustian, Anthony D. (2012). *Beware the Purple People Eaters: A Personal Look at Leadership*, Des Moines, IA: BookPress Publishing, p. 6.
3. Kaufman, Scott Barry. (2011, November 8). Why inspiration matters. Retrieved June 30, 2014, from the *Harvard Business Review* website: <http://blogs.hbr.org/2011/11/why-inspiration-matters>
4. Moore, G.E. (1965, April 19). Cramming more components onto integrated circuits. Retrieved October 18, 2011, from the *Intel* website: [ftp://download.intel.com/museum/Moores\\_Law/Articles-Press\\_Releases/Gordon\\_Moore\\_1965\\_Article.pdf](ftp://download.intel.com/museum/Moores_Law/Articles-Press_Releases/Gordon_Moore_1965_Article.pdf)
5. O'Neill, Leslie T. (2002, November). InfoWorld 100. pp. 35-45. *Thomas Edison* website: [www.thomasedison.com/biography.html](http://www.thomasedison.com/biography.html)
6. Developing the STEM education pipeline (2006). Retrieved June 24, 2014, from the *ACT* website: [www.act.org/research/policymakers/pdf/ACT\\_STEM\\_PolicyRpt.pdf](http://www.act.org/research/policymakers/pdf/ACT_STEM_PolicyRpt.pdf)
7. School Design, Classroom Layout Can Heavily Affect Student Grades, Learning: Study. Retrieved July 1, 2014, from the *Huffington Post* website: [www.huffingtonpost.com/2013/01/03/school-design-student-grades\\_n\\_2404289.html](http://www.huffingtonpost.com/2013/01/03/school-design-student-grades_n_2404289.html)

Join us March 2-6, 2015 for ciWeek 6 at the DMACC West Des Moines Campus. Keynotes and special presentations will be simulcast throughout the entire DMACC district.

[www.dmacc.edu/ciweek](http://www.dmacc.edu/ciweek)



# The **Celebrate! Innovation**<sup>™</sup> Exhibition: a showcase of American innovation that shapes life as we know it **today**.

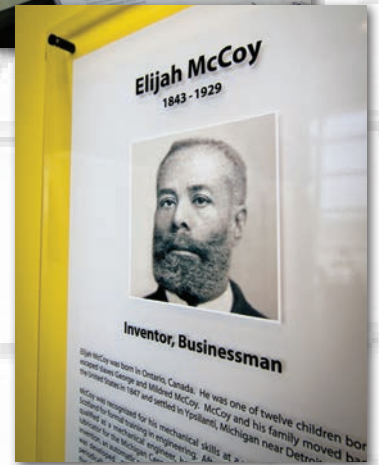

Through a collection of artifacts, visuals and digital video, visitors see firsthand how motivated people can solve a variety of everyday problems through creative and innovative thinking. For more information about this free, inspiring experience, go to [www.dmacc.edu/ci](http://www.dmacc.edu/ci).

**Celebrate!**<sup>™</sup>  
**INNOVATION**  
DES MOINES AREA COMMUNITY COLLEGE WEST CAMPUS

**DMACC**  
DES MOINES AREA  
COMMUNITY COLLEGE  
**Life's Calling**<sup>™</sup>

[www.dmacc.edu/ci](http://www.dmacc.edu/ci)

800-362-2127 | [www.dmacc.edu/west](http://www.dmacc.edu/west)



F R E E T O P U B L I C

# TO BOLDLY GO

CIWEEK 6  
MARCH  
2-6  
2015

5959 GRAND AVE., WDM IA

DMACC WEST CAMPUS



celebrate! innovation  
*week*

WWW.DMACC.EDU/CI





**LEVAR  
BURTON**

ACTOR, DIRECTOR  
& EDUCATOR



**DR. SARA  
SEAGER**

PLANETARY SCIENTIST &  
ASTROPHYSICIST



**DR. HUGH  
HERR**

BIONICS ENGINEER  
& ROCK CLIMBER



**CLAYTON  
ANDERSON**

SPACE SHUTTLE &  
ISS ASTRONAUT



**CASSIE  
LEE**

ENGINEER—  
DREAM CHASER®



**DR. DAVID  
GALLO**

OCEANOGRAPHER  
& EXPLORER



**NIALL  
McCANN**

BIOLOGIST, ADVENTURER,  
EXPLORER &  
CONSERVATIONIST



**DR. ANTHONY  
PAUSTIAN**

EDUCATOR, AUTHOR  
& DESIGNER



**DANNY  
BEYER**

NETWORKING NINJA,  
SPEAKER & AUTHOR



**TOM  
EAKIN**

AUTHOR  
& SPEAKER

PRESENTED BY

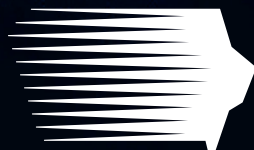

IOWA NETWORK SERVICES



SHIVEHATTERY  
ARCHITECTURE+ENGINEERING



then ...  
**Industrial**



and now ...  
**Inspirational**



then...  
**Institutional**



and now ...  
**Innovative**



# SHIVEHATTERY

ARCHITECTURE + ENGINEERING

New address. We planned, designed and leased it, and now ... moved in!

4125 Westown Parkway, Suite 100, West Des Moines, IA 50266

515.223.8104 [www.shive-hattery.com](http://www.shive-hattery.com)





A scenic view of Tassel Ridge Winery in Leighton. Used with permission.



BY BOB WERSEN

# AN UNLIKELY VINEYARD

## *The Tale of Tassel Ridge*

*You may have to search for them. Some hide behind typically Iowa crops: rows of corn, giant bales of hay. But if you drive far enough, off the interstates and onto highways, the stalks and bales sometimes give way to the winding vines and stunning foliage of the Iowa wine industry. Like those vines, the Iowa wine industry is alive and growing: today, approximately 1,200 acres of Iowa soil support some 300 vineyards and 100 wineries. These wineries can be found in 87 of Iowa's 99 counties, with a total economic impact of \$420 million, according to a 2012 study.*





Tassel Ridge has 68 acres of planted vines. Used with permission.

In the winter of 2000, nearly everyone who planted, or contemplated planting, grapes in Iowa with the hope of starting a winery was a pioneer. Although such pioneers remained doggedly optimistic, the wisdom of such a move was not obvious. Only a handful of Iowa wineries existed then, most new and most small. Furthermore, the vineyards were growing grape varieties new to Iowa, another unknown. However, Iowa depends on agriculture, and the time was ripe (all puns intended) to try something new. Corn and beans were selling for prices below the cost of production, with both pork and beef also losing money. Anyone with land—including acreages—contemplated alternatives.

I am not a farmer, but I did own land. Interested in finding a way to put the land to profitable work, I started studying grape growing. While attending conferences, meeting with Iowa and Illinois grape growers, and reading everything I could get my hands on, I

made an important discovery: Iowans don't drink much wine. In fact, we consume about 40 percent less wine than the national average, which places us near the bottom of the list. At the same time, we ranked closer to the top in per capita consumption of beer and spirits.

Sometimes, the perspective of inexperience can be a good thing. I didn't believe Iowans were that different from our neighbors in Illinois, where per capita wine consumption doubles ours. The challenge—and opportunity—became figuring out what factors were influencing our choices of alcoholic beverages.

I'd been a wine drinker for years. For me, the right wine paired with the right food made both taste better. I concluded if I could find a way to show Iowans how to pair wine with food, I could help increase the per capita consumption of wine in Iowa, and my winery—as well as others—would benefit. If the entire Iowa wine industry did the same, we collectively could take market share,



The right wine paired with the right food makes each taste better. Used with permission.

which would translate into wealth in rural Iowa.

## Challenges in the Vineyard

My wife Sharman and I started planting vines in 2002, with the help of staff to do the planting and vineyard maintenance. Sharman and I decided which varieties to plant; however, location was an important part of that decision. I immediately started looking and discovered an 87-acre site on Highway 163 near Leighton, about ten miles southeast of Pella. We finished the land purchase in 2003; by 2004, we started construction. We continued planting more vineyards each year while the winery was finished. We then made wine and hired staff for our tasting room.

We quickly learned you can't open a winery in Iowa without a product line. People aren't picky; they simply want dry and sweet wines, whites and reds, and maybe a fruit wine or two. To





Tassel Ridge visitors taste a wide range of wines after touring the winery and vineyard. Used with permission.

accommodate these desires, we used grapes grown in our vineyards for some of our dry red and white wines as well as our semi-sweet rosés; plus we purchased grapes in California and fruit juice in upstate New York. Finally, by May 2006, Tassel Ridge Winery opened its doors.

We still had much to learn, of course. Growing the right grape varieties proved more complicated than expected. It turned out grape varieties that did well in Missouri—varieties such as Norton, Chardonnay, St. Vincent and Chambourcin—did not automatically produce well in Iowa. At the time, we ripened Norton in our Mahaska County vineyards, so we replaced it with Steuben in 2003. But Steuben has its own problems, as do the French-American grape varieties such as Foch. Through trial and error, we discovered French-American and *Vitis Labrusca* varieties generally don't ripen until late in the season, leaving us exposed to the weather if we get an early October frost.

We settled on northern climate grape varieties, most of which are crosses between *Vitis Riparia* and *Vitis Labrusca*, two grapes native to the U.S. All of the northern climate varieties we now grow were developed by Elmer Swenson in western Wisconsin and at the University of Minnesota. These varieties seem well-suited for Iowa; they survive our winters and ripen in our short growing seasons. Depending on the variety, they are ready for harvest beginning as early as August 15. We usually finish harvesting our grapes by mid-September.

Patience is needed throughout the process, especially the discovery of what works and what doesn't. Vines take about 2½ years to produce their first grapes. Depending on the wine, it may be five years before we know what we've got in terms of wine quality. The adage "patience is a virtue" certainly applies to growing grapes and making wines!

Tassel Ridge established four vineyards in Mahaska County at the winery and

around Oskaloosa. The biggest of these vineyards is at Tassel Ridge. Our other vineyards include Meadowcreek Vineyard on the north edge of Oskaloosa, Maple Woods Vineyard on the east edge of Oskaloosa, and Newport Lane Vineyard in northeast Oskaloosa. Altogether, we produce grapes on 68 acres of Iowa land.

*Sometimes, the perspective of inexperience can be a good thing.*





Simply Extraordinary, the Tassel Ridge Winery magazine. Used with permission.

## Promote or Die on the Vine

The challenges continue. One is the need for promotion. How do we let people know we are growing grapes and producing Iowa wine? How can we motivate them to visit the winery and enjoy our product? Through trial and error, we have landed on promotional strategies that work, such as a weekly e-letter and a quarterly magazine. We try to hit local news media hard, by advertising in several Iowa magazines and on 14 different Iowa radio stations. Finally, we developed and maintain an online presence through our website. Our promotional activities garner about 12,000 visits per year. Visitors to our website discover delicious recipes that pair well with our wines, updates on what is happening in the vineyards and cellar, and suggestions of places to visit in the area.

*Patience is needed throughout the process, especially the discovery of what works and what doesn't.*

To witness a wine pairing in action, Tassel Ridge Winery offers Friday and Saturday dinners where our chef prepares a meal paired with a specific wine. Menus range from Wine and Burger Nights, to Wine and Pasta Nights, to full, multi-course dinners such as our Red Wine Lovers' dinners, which focus on meals that pair well with our dry reds. A highlight of these events typically includes a trip to the cellar where we will taste one or more wines

not yet bottled. Normally, we provide a recipe card with instructions for making our meals at home. While it is wonderful to enjoy a special night out with like-minded friends, we also hope people will discover the simple pleasures of consuming a fine wine with everyday meals as well.

## Wholesale Strategies

Although my initial dream was to sell our wines at the winery, by August 2006 (three months after opening), I realized a new strategy would be needed, so I started preparing to sell our wines at wholesale to retailers. Wine is a convenience. Many people won't drive far to purchase that special bottle of wine. In fact, most people purchase their wine in the same places they buy their food. So, in the fall of 2006, we built a network of retailers across Iowa.





Tassel Ridge Ambassadors conduct tastings at retailers that carry Tassel Ridge wines. Used with permission.



Tassel Ridge offers dry and sweet wines, whites and reds, and two fruit wines. Used with permission.



Bob Wersen is the founder and co-owner of Tassel Ridge Winery in Leighton, Iowa. He started working on his vineyard and winery project in 1999 and began planting what is now 68 acres of vineyards in Mahaska County in 2002. Tassel Ridge Winery opened to the public in May 2006 and now produces and bottles more than 30,000 gallons of wine each year. Tassel Ridge wines are currently sold at more than 400 retailers in Iowa.

Wersen is no stranger to entrepreneurship. Tassel Ridge Winery is his fourth start-up. His most successful start-up is Interpower Corporation, a company he founded in 1975. As president, he watched Interpower grow to about 80 employees in three Iowa locations, and it includes a wholly owned subsidiary based in the United Kingdom.

Wersen grew up in Los Angeles, California, and earned a B.A. and an M.B.A. from the University of California at Berkeley. His business studies focused on marketing, and he is building Interpower Corporation and Tassel Ridge Winery with ongoing marketing campaigns and programs.

<http://tasselridge.com>

A rude awakening came when we discovered most retailers were waiting for our sales rep to show up. While a small percentage of retailers willingly gave our wines a try, securing dedicated shelf space for our wines took several visits. Store managers wanted to be sure we weren't going to drop off wine, then disappear.

We realized if we did a tasting in a retail establishment, retail sales of Tassel Ridge wine increased quickly. Initially, our tastings were conducted by our sales reps; however, after several months, we recruited a group of part-

time employees we called Ambassadors to conduct tastings. We now have about 25 Ambassadors.

Looking back over the eight years of winery operations, the biggest surprises related to how capital-intensive a winery is. Our vineyards cost about \$16,000 per acre to install and get to production. A jacketed 2,000-gallon wine tank costs about \$14,000, and if that tank is jacketed and insulated, the cost is closer to \$24,000. A press costs \$40,000 to \$50,000 depending on size. And the need for necessary equipment doesn't end.

Finally, while a wholesale element of a winery's overall strategy is important, the costs of wholesale make it almost impossible for a winery to depend solely on wholesale revenue. At Tassel Ridge, the objective is to get our revenue balanced equally between wholesale and retail over the next three to four years.



---

DREAM & BUILD AN  
**INNOVATIVE IDEA**  
& ALLOW IT TO SHINE

---

WE BUILD. DREAM. GROW. INNOVATE. WE MAKE A DIFFERENCE.



In pursuit of  
**building perfection®**

5959 Village View, Suite 100  
West Des Moines, Iowa 50266  
515.698.4400 | [www.jedunn.com](http://www.jedunn.com)



# GREATEST, RECOGNIZED.



#1

"WEALTHIEST CITY  
IN AMERICA"

NBC'S TODAY SHOW, 2014

#2

"BEST PLACES FOR  
BUSINESS"

FORBES, 2014

#1

"STRONGEST LOCAL  
ECONOMY"

POLICOM CORPORATION, 2014

The Greater Des Moines Partnership is the economic and community development organization serving Central Iowa. The Partnership is a proud sponsor of Innovation Week and believes that our community's prosperity stems from

## FEARLESS THINKING AND BOLD IDEAS

By supporting our innovators, we are supporting the future of our region.

[www.desmoinesmetro.com](http://www.desmoinesmetro.com)





Tassel Ridge®  
*Iowa Marquette*  
one wine...three vintages!

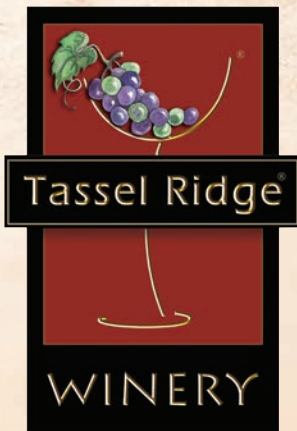

**Savor** the aromas of dried figs, blackberry, and baking spices.

**Taste** the hints of blackberry, plum, dark chocolate, and white pepper.

**Pair** these balanced, dry red wines with steak or prime rib.

**Serve** at room temperature.

1681 220<sup>th</sup> St., Leighton, IA 50143 • between Pella and Oskaloosa on Hwy. 163

641.672.WINE (9463) • [www.tasselridge.com](http://www.tasselridge.com)

Tassel Ridge wines are sold at the Winery and over 400 retailers in Iowa. For a complete list of retailers, visit [www.tasselridge.com/retail](http://www.tasselridge.com/retail). Order wine by telephone at 641.672.WINE (9463). We offer shipping within Iowa and to select states. Adult signature required for receipt of wine.

Tassel Ridge Iowa Marquette...*Simply Extraordinary*®







Blaine Labs VAD Product

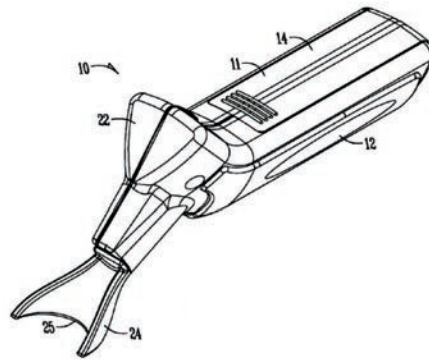

U.S. Patent 8,449,482 5/28/2013

## Step 1: Capturing Innovation

Whether innovation derives from sweat of the brow or a flash of genius, the value and cost may be substantial. Some innovation is the result of extensive research and development, while other ideas may require significant testing and prototype work. Most commercially successful innovations also require substantial marketing efforts. Therefore, the proper protection of such innovation is important.

Failure to plan is, in essence, a plan to fail. Thus, it is wise to have a strategic plan, so inventors can maximize the value of newly developed or discovered inventions. Otherwise, opportunities may be lost, and competitors may encroach without recourse.

First, every employee and officer of a company should sign a written employment agreement that assures any inventions relating to the company business will be owned by the company. Next, there should be a policy regarding submission of ideas and developments. Invention submission forms may be useful in capturing key information such as a brief description of the invention, the problems in the prior art, and the benefits provided by the invention. The

forms should be signed and dated by the inventor(s) and at least one witness.

## Step 2: Evaluating Innovation

To obtain a patent, an invention must be new and distinctive. The evaluation needs to reach a relatively quick decision on whether to proceed with possible patent protection. The evaluation may be done in-house or may involve outside patent counsel. Time is of the essence.

To determine whether a development or innovation is patentable, a patent search can be conducted. While such a search is not mandatory, the search may save substantial time and money if it is discovered the invention is not new or is an obvious variation of prior art. Ideally, at a minimum, the search should cover U.S. patents and published applications. The search may also be extended to publicly available literature, commercially available products, foreign patent offices, foreign literature and other publicly available information. The search results can also help define the scope of patent protection. Knowledge of relevant prior art can be helpful when drafting the patent application, so that distinctions from prior patents can be identified and emphasized.

Be wary of invention development companies. Despite grandiose promises, many have little, if any, chance of returning more than is paid to them.

## Step 3: Establishing Objectives

Business objectives usually affect the strategies used for protecting innovations. For example, do you want to prevent others from copying your commercial product, or do you want to also control the market for variations of your product? The answer to this affects the scope of the application and may potentially increase or decrease the prosecution pendency and costs of the application(s) in the patent office.

Do you want to primarily deter potential competitors, so you can get a head start in the marketplace by using “patent pending” on the product and on promotional literature? Since a patent application remains confidential for a minimum of 18 months after the filing date, competitors do not know when the application was filed or the scope of coverage sought by the applicant. Therefore, the competitor has some risk due to the unknown status of the patent application. Even if ultimate issuance of a patent is an uphill battle, “patent pending” status for three to five years, or more, may provide value far exceeding the cost of the patent application. Also, marking a product as “patent pending” has a connotation of something new and unique, which may provide marketing value.

Are you building a patent portfolio for potential sale of the company? If so, quantity may be as important as quality. Multiple applications may be filed, each of which is narrowly focused, or a single application may be filed covering multiple features. There may also be value in maintaining a continuing chain of applications.



Is a patent application simply a defensive maneuver to prevent a competitor from obtaining a patent? Even if patent issuance is a long shot, publication of the patent application by the U.S. Patent office may prevent a competitor from getting a patent.

Sometimes, a patent may be obtained on the big picture, such as the entire machine, product or process. Other times, only the pieces of the picture can be patented. However, patenting multiple pieces of the puzzle may, in effect, substantially cover the whole picture.

Similarly, sometimes an invention may include both a process and a product or apparatus with one or more patents directed to these different aspects of the invention. Multiple patents can extend the scope of protection and increase the value to the patent owner.

Many inventions continue to be improved year after year. For such innovations, a new application can be filed for each new improvement and thereby extend the protection for the commercial embodiment beyond the life of the first patent on the original invention.

*Whether innovation derives from sweat of the brow or a flash of genius, the value and cost may be substantial.*

A U.S. patent is only enforceable within the United States against those who make, sell, offer to sell, or use the patented invention. Thus, the U.S. patent will protect against imports and exports but will have no effect if the invention is made or stays abroad. Therefore, foreign patent protection may be a consideration for companies, particularly if they have overseas markets. However, foreign protection is forfeited in most countries if there is any public disclosure of the invention before the first application is filed.

There are several options for foreign patent protection. For United States inventors, foreign applications are usually based on the U.S. application

and can claim priority to the U.S. application if filed within one year of the U.S. application (six months in the case of a design application). You can select specific countries in which to proceed directly with a patent application. There are also regional patents such as a European patent, which covers more than 30 countries on the continent and regional patents for certain countries in Africa and Eurasia.

Another option for foreign patent protection is the filing of a single application under the Patent Cooperation Treaty (PCT), which then buys another 18 months before specific countries or regional patents need to be designated.

**Step 4:  
Choosing the Best Options**

In the United States, patents can be granted on any new and useful process, machine, product, composition as well as improvements to these categories. The U.S. Patent and Trademark Office issues three types of patents: utility patents, design patents and plant patents (which are beyond the scope of this article). Some inventions are subject to protection with both a utility and design patent. The utility patent



TriMark RV door handle

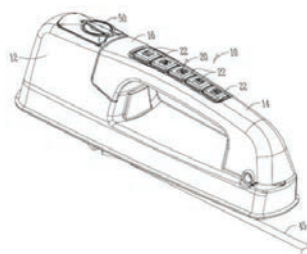

Pending U.S. patent application

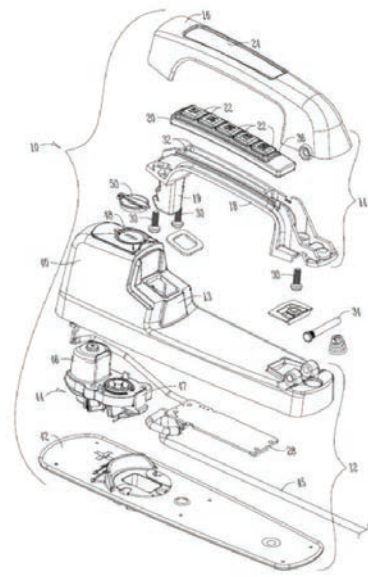

*Patenting multiple pieces of the puzzle may, in effect, substantially cover the whole picture.*

generally protects structural and functional features whereas a design patent only protects the ornamental, nonfunctional features of a physical object. While design patents are often considered narrower in scope than a utility patent, a design patent offers an additional or alternative scope of protection. In some instances, a design patent may be issued while a utility patent on the same subject matter is denied. Normally, an application for design patent progresses faster through the Patent office than a utility application and at less cost. A design patent is valid for 14 years from the issue date, whereas a utility patent has a life of 20 years from the filing date (with some exceptions).

A utility application includes a complete written description of the invention and usually illustrations. Once the utility application is filed, the Patent office examination process begins. Most utility applications receive an initial rejection from the Patent office examiner for one or more reasons, the most common being that the claimed invention is obvious in view of the prior art. The applicant then can respond to the examiner, providing clarification, explanation, modification and/or narrowing the scope of the application. There may be several rounds of negotiations between the applicant and the Patent office, which ultimately and hopefully lead to issuance of the patent.



Wand Wizard pressure washer coupler

According to Patent office statistics, the average pendency of a utility application is approximately three years. The pendency time may increase or decrease, depending in part on whether the applicant and examiner can agree upon the appropriate scope of protection, that is, what the applicant is willing to accept compared to what the examiner is willing to allow.

A provisional application, often an abbreviated application, is (in effect) a tool to buy time before filing the utility application. Like a utility application, a provisional application receives a filing date and a serial number, has “patent pending” status, and is confidential in the Patent office. However, a provisional patent application is not examined, but rather merely preserves the applicant’s rights for one year. A provisional application must be converted to a utility application within 12 months; otherwise, the provisional application expires.

A provisional application has pros and cons. In many instances, a provisional application is a less expensive way to get the patent process started.

However, a provisional application also adds to the overall time before a patent issues, since examination does not start until a utility application is filed. Business objectives may dictate

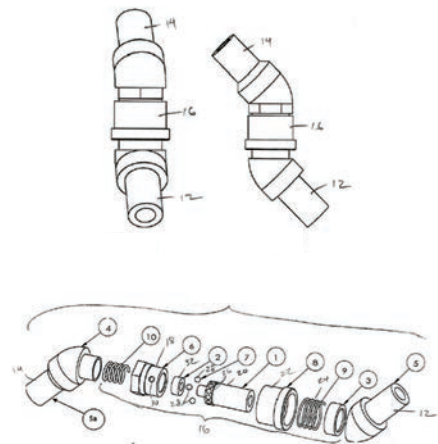

Pending U.S. Patent application.

whether to file a provisional application or start with a utility application. For example, if an innovative product is going to be marketed before a patent issues, the goal may be to get the patent in hand as quickly as possible so as to have enforceable rights against competitors. If the invention is still in the development stage, a provisional application may be justified before the development is finalized or confirmed. If time is needed to find partners for manufacturing, marketing, distribution and/or financial support, a provisional application may be a good choice.

In the United States, the patent laws permit commercial exploitation of the invention before a patent application must be filed. Therefore, an inventor or company can offer the invention for sale, display the invention at a trade show, disclose the invention on a website, or otherwise test market the invention for up to one year before filing a provisional or utility patent application. However, new applicants must remember how this affects patent protection in most foreign countries. Thus, an application should be filed before any public disclosure if foreign patent protection is important.

Some inventions continue to evolve during research and development. In



these instances, the timing for filing a patent application may be more problematic. The business objectives again become important in determining when to file the application. The race to the Patent office may be also a factor. Multiple patent applications may be necessary or desirable as the product development continues and is finalized.

Once the patent office examiner issues a Notice of Allowance, and before the patent issues, consideration should be given as to whether any related applications should be filed. For example, the parent application may be directed to the product while a related child application may be directed to the process for making the product. A design application to cover the appearance of the product may be appropriate in some cases. If improvements have been made to the original invention, a new application directed to the improvements may be in order. Such applications may be precluded after issuance of the parent patent due to the one-year statutory bar (public disclosure more than a year before the filing date). Also, the parent patent will be prior art if the second application is filed after the parent issues.

## Step 5: Policing and Enforcing Patent Rights

Once the patent issues, the patent number should be used in connection with all commercialization of the invention, if possible. For example, for a patented product, the patent number should be marked on the product and on the promotional literature. Virtual patent marking may also be used such as a decal on the product identifying a web page with patent numbers. Otherwise, rights may be lost in the event of infringement.

Furthermore, the patent owner should take action to watch and police the industry for competitors who may

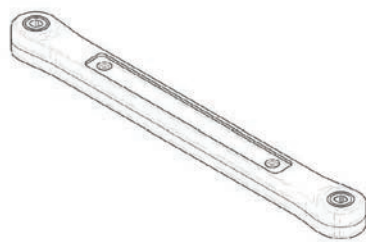

U.S. Patent D607,289 1/5/2010



Tite Reach Wrench

infringe the patent. For example, a plan of action should be in place to educate the appropriate people, including management and the sales force, about each new patent and the patent portfolio so as to keep an eye open for potential infringement problems. Regularly scheduled searches on the Internet can be conducted to monitor competitors' conduct. Infringement concerns should be promptly brought to the attention of in-house or outside counsel. Quick action will often reduce damages, save costs and resolve any disputes in a more timely and economical manner.

A business plan for intellectual property may provide substantial value to the company or may be leaving substantial value on the table. A thorough plan, properly executed, can provide protection for innovations and payback for research and development expenditures.

Through the wisdom of our country's founding fathers, the U.S. Constitution provides a means for promoting and protecting the progress of science and technology by securing the exclusive rights to inventions for limited times.

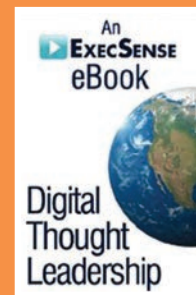

Kirk M. Hartung is a patent attorney practicing in Des Moines with McKee, Voorhees & Sease, an intellectual property boutique law firm with 18 lawyers. With more than 30 years of experience, Hartung advises inventors on the options for protecting their innovations and ideas. Kirk evaluates patentability, writes patent applications, prosecutes in the U.S. and foreign patent offices, negotiates and litigates patent disputes, and secures licensing and transfers of patent rights. Kirk is the author of *Digital Thought Leadership*, and his engineering and law degrees provide the technical and legal backgrounds to assist clients in their intellectual property matters.

[www.ipmvs.com/users/kirkhartung](http://www.ipmvs.com/users/kirkhartung)

While the 2011 America Invents Act made the most significant changes to the U.S. patent laws since 1952, the benefits of patent protection still can provide significant value for any company's innovations.

*Make your stay elegant and rewarding*



**Holiday Inn**  
& Suites

*Johnny's*  
Italian Steakhouse®





*Of all the gifts  
that can be given,  
the gift of education  
is perhaps the greatest.*



The Des Moines Area Community College Foundation ensures educational excellence through charitable giving. Our vision is to provide every student access to a quality education to pursue opportunities and achieve career dreams.

### **2014 DMACC FOUNDATION HIGHLIGHTS**

- ▶ **Allocated more than \$700,000 in scholarships to support more than 1,000 DMACC students.**
- ▶ **Assisted 1,252 adults to achieve their dream of earning a GED through the GED Test Closeout Campaign.**
- ▶ **Raised \$208,000 for scholarships through the 7th Annual DMACC CEO Golf Invitational.**
- ▶ **Provided 565 students access to English as a Second Language courses.**
- ▶ **Launched the first DMACC Foundation Entrepreneurship Competition and awarded a \$10,000 cash prize.**



The DMACC Foundation supports the College in areas that are not sustained by taxes, tuition or grants.

Learn how you can make the dream of a college education possible.

**[www.DMACC.edu/Foundation](http://www.DMACC.edu/Foundation)**

# E-X-P-A-N-D-I-N-G

THE  
MINDS  
.....OF OUR.....  
FUTURE  
GRADUATES



[www.dmacc.edu](http://www.dmacc.edu)

800-362-2127  
[www.dmacc.edu/west](http://www.dmacc.edu/west)

**DMACC**  
DES MOINES AREA  
COMMUNITY COLLEGE  
**Life's Calling™**

5180-9-14-1-500